

Energy products

Gas metering valve C421895

Three-inch flange, 90 to 140 vdc,
electromechanically actuated (EMA)



Meggitt's three-inch globe style gas metering valve is designed for use on a variety of industrial gas turbines. This product utilizes the same high reliability features as all Meggitt electric gas metering valves.

Specifications

Function:	Precision fuel gas metering for aero-derivative turbine engine control
Physical size:	12.5" flange to flange, 9.78" wide, 28" high
Weight:	120 pounds
Flange type:	3" ANSI B16.5 CL 600 raised face flanges
Line pressure:	0 to 350 psia
Fluid temperature:	32 to 300°F
Ambient temperature:	-65 to 150°F
Performance:	
Flow:	Linearly proportional to valve stroke
Internal leakage:	ANSI class IV
Operating time:	175 msec full stroke response, 150 msec 50% step response, 300 msec fail-safe closed (power loss)
Electrical:	
Motor:	Steady state, 90 to 140 VDC, 0.50 amperes; 10 amperes maximum transient (100 msec)
Resolver:	4 VAC, 25 to 60 ma maximum
Closed position indicating switch:	SPDT
Thermostat:	Opens at 329 to 347°F; resets at 251 to 270°F

Key features

- Accuracy, $\pm 3\%$ of flow point
- High speed brushless DC servo motor performance, 20 Hz frequency response
- 175 msec full stroke response time
- Used on both DLE and SAC turbine engines
- Explosion proof design, CSA/UL certified for NEC class 1, division 1, groups C and D, temp code T4, CE EExd IIB, Zone 1, CE-ATEX certified
- All stainless steel valve and yoke materials for NACE compliance
- No maintenance required under normal conditions

Meggitt Control Systems

Our product competencies & services:
Aerospace valves | Thermal management solutions | Environmental control systems | Electro-mechanical products
Ground fueling products | **Energy products** | Aftermarket services

MEGGITT
smart engineering for
extreme environments

Energy products

Gas metering valve C421895

Key dimensions

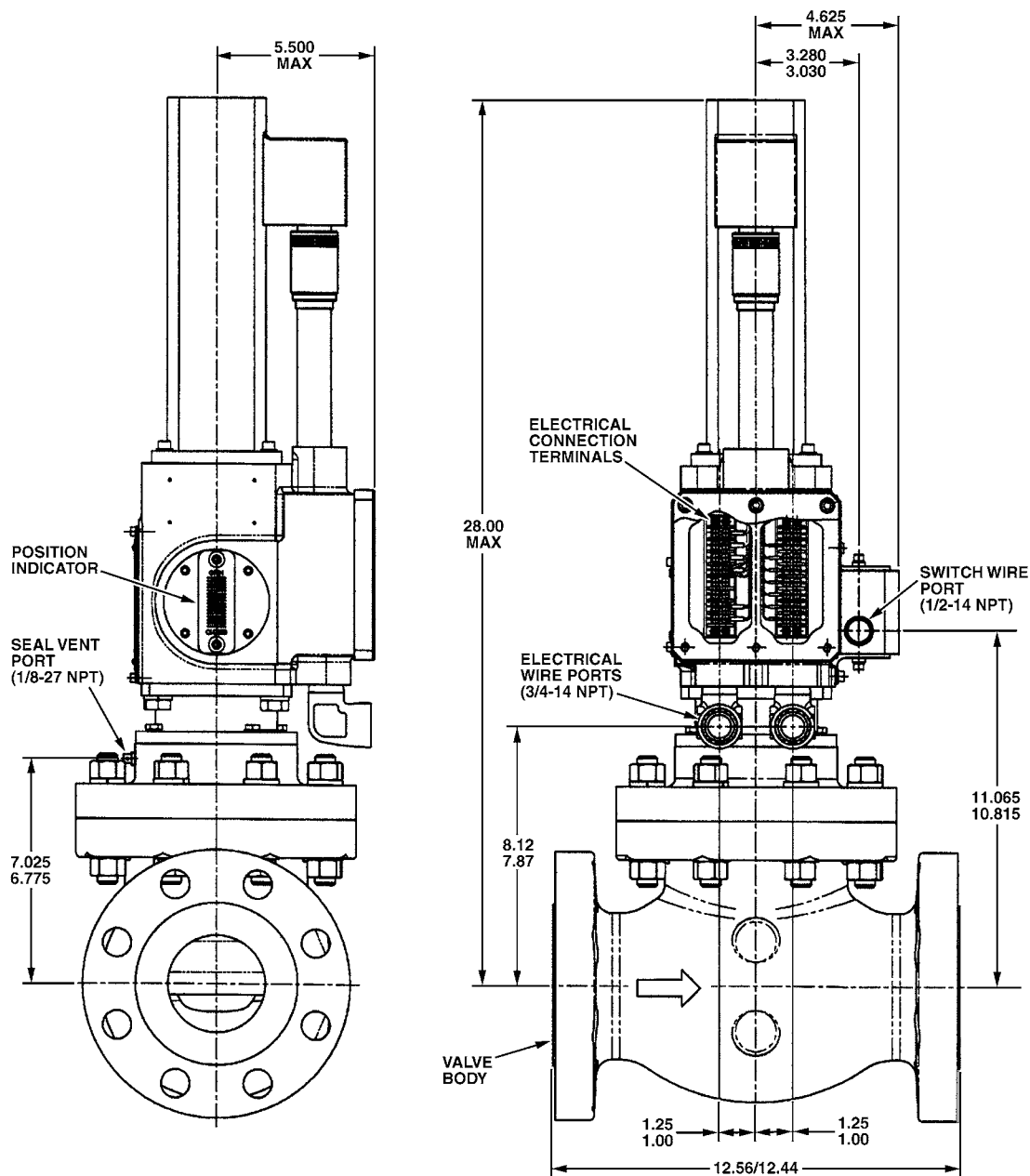

NOTE: DIMENSIONS SHOWN ARE IN INCHES

Contact

Meggitt Controls

12838 Saticoy St
North Hollywood
California 91605-3505
USA

Telephone: (818) 765-8160
FAX: (818) 759-2194

www.meggitt.com

Meggitt Control Systems

Our product competencies & services:
Aerospace valves | Thermal management solutions | Environmental control systems | Electro-mechanical products
Ground fueling products | Energy products | Aftermarket services

MEGGITT
smart engineering for
extreme environments